

Caractéristiques de la machine:

1. Ces machines à capes à froid sont entièrement automatiques et faciles à utiliser avec peu d'entraînement, équipées d'une matrice solide pour produire des boulons, des vis, des rivets et d'autres composants similaires. Le mécanisme de coupure et de suppression a des appareils en toute sécurité qui arrêteront tout accident majeur si une fonction anormale se produit dans les machines.
2. Une disposition positive à élimination directe avait été faite sur les 1er et 2e coups de poing pour éliminer la possibilité de pièces qui se collaient à ces coups de poing pendant les opérations.
3. Sur certains charges supplémentaires, les machines seront équipées d'embrayage pneumatique et de systèmes de lubrifications centralisés automatiques qui fournit une quantité suffisante de lubrification à toutes les surfaces de roulement.



PRODUCTION AREA

Provide You With A Variety Of Products Meet
The Different Needs Of Customers



Screw With Washer



Multi-stage
Special Shaped Screw



Flange Head Screw



Ordinary Screw



Miniature Screw



Semi-hollow Rivet

DETAILS SHOW

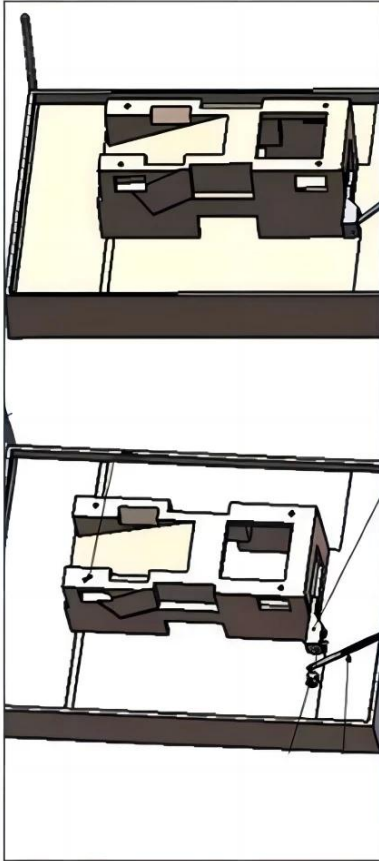

Heading machine is the fastener industry whole plant equipment with automatic thread rolling machine supporting the professional equipment cold heading machine. Its purpose is selected, such as carbon steel, stainless steel, aluminum, copper and other metal wire, with a suitable mold, according to wire made allowable pressure ratio in effect under the slider crank rod driven,

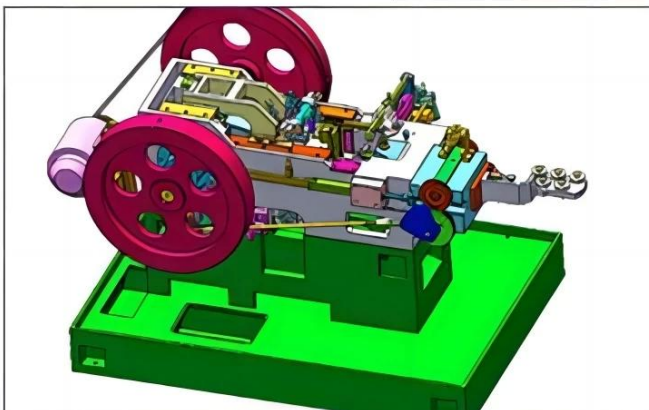
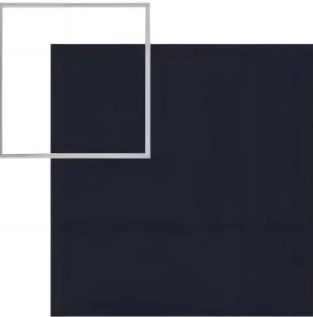

SAFETY INSTRUCTIONS

The head machine is a professional cold upsetting forming machine which is matched with automatic wire rolling machine in the whole plant of fastener industry.

Its purpose is to the selected such as carbon steel, stainless steel, aluminum, copper and other metal wire, with appropriate mould, according to the allowable pressure wire than, under the effect of crank-shaft connecting rod drive the slider, automated, fast after the required size of the wire will be automatically shear, extrusion in the mould for needed fastener head type, stem diameter, facilitate thread rolling, or become a qualified rivet type fastener. The heading machine automatically processes the wire into semi-finished products.



- 1 Le cadre du corps est en soudage de plaque de fer
- 2 pièces de rechange sont fabriquées à partir de la coulée
- 3 pièces intérieures sont en acier de roulement



SCREW MAKER

One die two blow heading machine. widely used to produce standard and non-standard screw. the machine is easy to operate and stable in performance



PRODUCTION AREA

Provide You With A Variety Of Products Meet
The Different Needs Of Customers



Screw With Washer



Multi-stage
Special Shaped Screw



Flange Head Screw



Ordinary Screw



Miniature Screw



Semi-hollow Rivet

DETAILS SHOW

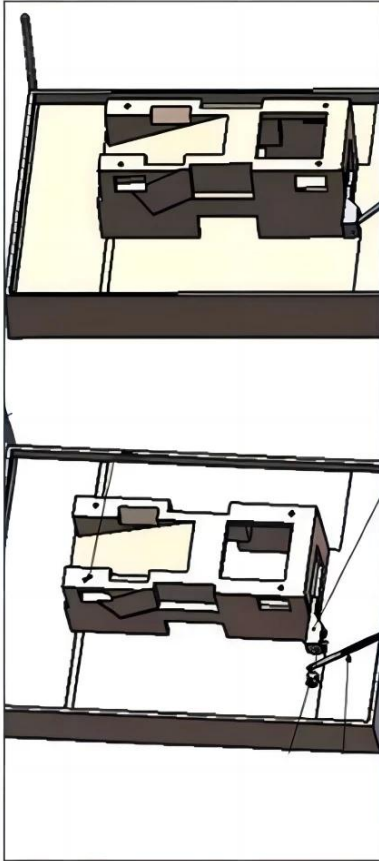

Heading machine is the fastener industry whole plant equipment with automatic thread rolling machine supporting the professional equipment cold heading machine. Its purpose is selected, such as carbon steel, stainless steel, aluminum, copper and other metal wire, with a suitable mold, according to wire made allowable pressure ratio in effect under the slider crank rod driven,

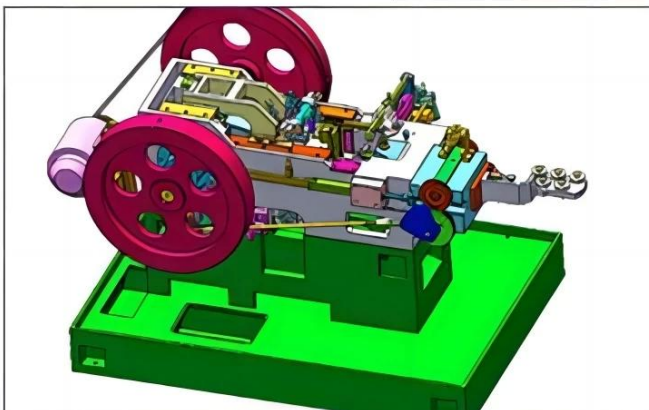
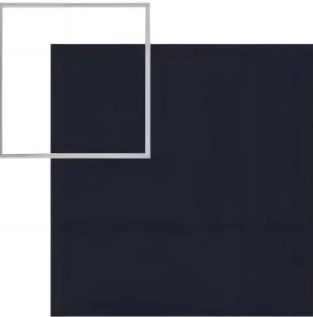

SAFETY INSTRUCTIONS

The head machine is a professional cold upsetting forming machine which is matched with automatic wire rolling machine in the whole plant of fastener industry.

Its purpose is to the selected such as carbon steel, stainless steel, aluminum, copper and other metal wire, with appropriate mould, according to the allowable pressure wire than, under the effect of crank-shaft connecting rod drive the slider, automated, fast after the required size of the wire will be automatically shear, extrusion in the mould for needed fastener head type, stem diameter, facilitate thread rolling, or become a qualified rivet type fastener. The heading machine automatically processes the wire into semi-finished products.

