

Well Tipo de forno de recozimento ELECTRIC

Well Type Electric Annealing Furnace



Liner of Well Type Electric Annealing Furnace



Well Type Electric Annealing Furnace (Main Furnace)



Electric Control Cabinet



Blower

Aplicação: Aplicado principalmente no esferoidização recozimento de bobina de fio de aço de baixo

carbono, aço, e aço do rolamento.

Cumprir a exigência profunda transformação das propriedades mecânicas do aço após heatment. Ele adquire descarbonização não-oxidação, a uniformidade do tecido esferoidização e boa qualidade de deformação plástica a frio (como estampagem e forjamento a frio).

Bem estrutura do tipo pode ser enterrado no subsolo, por isso ocupa pequena área; adota aquecimento elétrico e do processo heatment automática.

O revestimento do forno adota fibra completo, eficiência térmica e conservação de energia altamente promovido. O topo do forno é equipado com ventilador forte convecção de modo que a uniformidade da temperatura do forno todo é bom (+ - 5 °C).; adoção de gás de protecção e não-oxidação heatment para reduzir a perda de metal; material de alimentação é conveniente.

loadage acima é para fio de ferro para sua referência. As mudanças loadage acordo com Dia, altura e peso de fios de ferro.

ZD-8355型井式超强对流球化退火炉结构示意图

ZD-8355 Type supercon type spheroidizing Annealing furnace schematic diagram

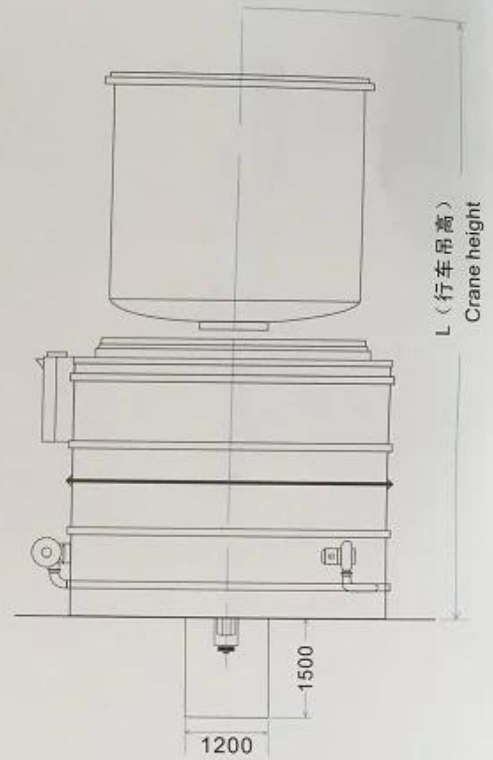
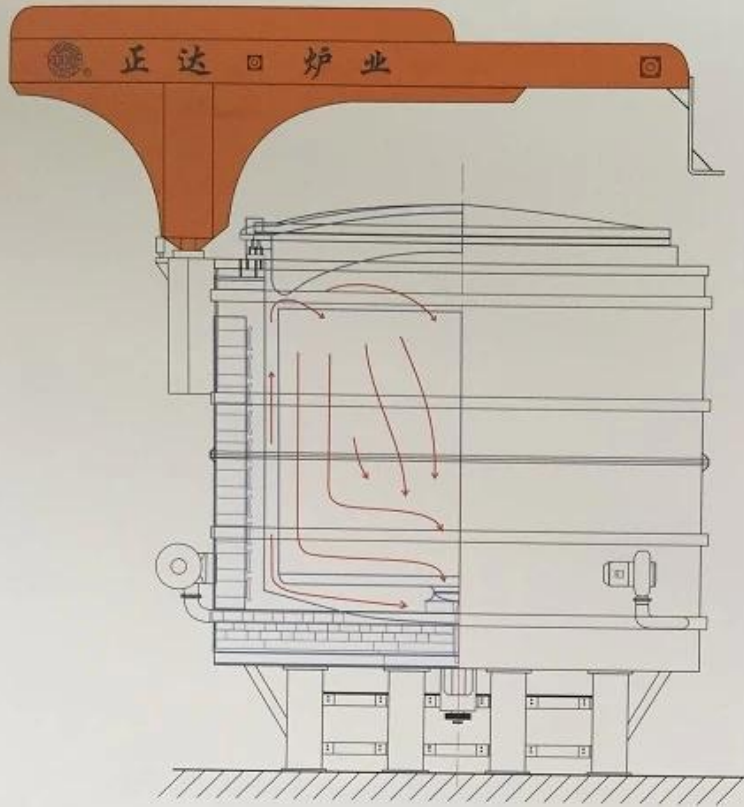

炉体安装吊高 (无脚架)
Installation lifting of furnace body

组成部件 Components



炉盖
The furnace cover



导流板
Air deflector



置料架
Loading frame



波纹桶成型
Corrugated molding



电加热炉
Electric heating furnace



波纹桶
Corrugated bucket



用于标准件行业球化炉
Used for fastener industry



用于汽配行业球化炉
Used for the auto parts industry



用于五金工具行业球化炉
Used for the hardware tool industry



用于轴承行业球化炉
Used for the bearing industry

超强对流型井式球化退火炉相关尺寸一览表(电加热型)
The relevant size list (Electric heating)

单位: mm

型号 Type	使用直径 Use diameter	使用高度 Use height	炉体外径 Furnace body diameter	炉体高度 Furnace body height	总高度 Total height	脚架高 Tripod height	行车吊高 Crane height		地坑尺寸 Pit size	维修坑尺寸 Repair pit size	炉体总重 Furnace weight	行车荷重 Driving load	功率 Power	装载量 Capacity
	A	B	D	B	E	F	有脚 size supporting table	无脚 No supporting table	G×J	长×宽×深 Length×Width×Height	(吨) Ton	(吨) Ton	(千瓦) Kw	(吨) Ton
8355-1	2200	2000	3378	3200	6930	1500	7800	6300	5200×5200	5200×1200×1500	19.8	5	240	2~8
	2200	3000	3378	4200	7930	1500	8800	7300	5200×5200	5200×1200×1500	22.8	5	240	2~8
8355-2	2450	2000	3678	3200	6930	1500	7800	6300	5450×5200	5450×1200×1500	21.8	5	280	4~14
	2450	3000	3678	4200	7930	1500	8800	7300	5450×5200	5450×1200×1500	25.8	5	280	4~14
8355-3	2800	2000	3978	3200	6930	1500	7800	6300	5800×5800	5800×1200×1500	26.2	5	400	4~14
	2800	3000	3978	4200	7930	1500	8800	7300	5800×5800	5800×1200×1500	28.5	5	400	8~16
8355-4	3200	2000	4378	3200	6930	1500	7800	6300	6200×6200	6200×1200×1500	29.3	10	500	8~22
	3200	3000	4378	4200	7930	1500	9800	8300	6200×6200	6200×1200×1500	32.5	10	500	8~22
8355-5	3600	2000	4778	3200	6930	1500	8050	6550	6500×6500	6500×1200×1500	34.3	10	640	8~32
	3600	3000	4778	4200	7930	1500	9950	8450	6500×6500	6500×1200×1500	35.2	10	640	8~32
8355-6	3700	2000	4978	3200	6930	1500	8050	6550	6700×6700	6700×1200×1500	35.3	10	720	8~36
	3700	3000	4978	4200	7930	1500	9990	8450	6700×6700	6700×1200×1500	36.3	10	720	8~36



Para mais informações, por favor visite nosso website: www.rainbowtechnology.net
Tem alguma dúvida, não hesite em contactar-me.
Muitas felicidades,
Vera

WhatsApp é: 8618704610523

Nós chat: vera5266

QQ: 417651303