

Caratteristiche della macchina:

1. Queste macchine per l'intestazione fredda sono completamente automatiche e facili da usare con poca formazione, dotate di madri solide per produrre vuoti per bulloni, viti, rivetti e altri componenti simili. Il meccanismo di taglio e knock-out ha dispositivi in sicurezza che fermeranno qualsiasi incidente grave se si verifica una funzione anormale nelle macchine.
2. È stata fatta una disposizione positiva knock-out sul 1° e 2° pugno per eliminare la possibilità che le parti si attaccassero a questi pugni durante le operazioni.
3. Su alcune cariche extra, le macchine saranno dotate di frizione pneumatica e sistemi di lubrificazione centralizzati automatici che forniscono una quantità sufficiente di lubrificazione a tutta la superficie del cuscinetto.



PRODUCTION AREA

Provide You With A Variety Of Products Meet
The Different Needs Of Customers



Screw With Washer



Multi-stage
Special Shaped Screw



Flange Head Screw



Ordinary Screw

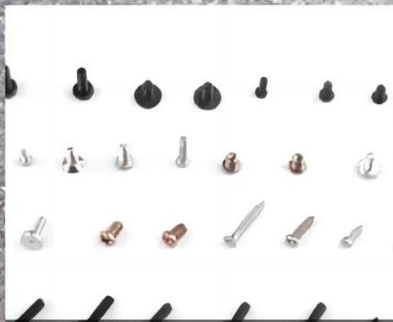

Miniature Screw



Semi-hollow Rivet

DETAILS SHOW

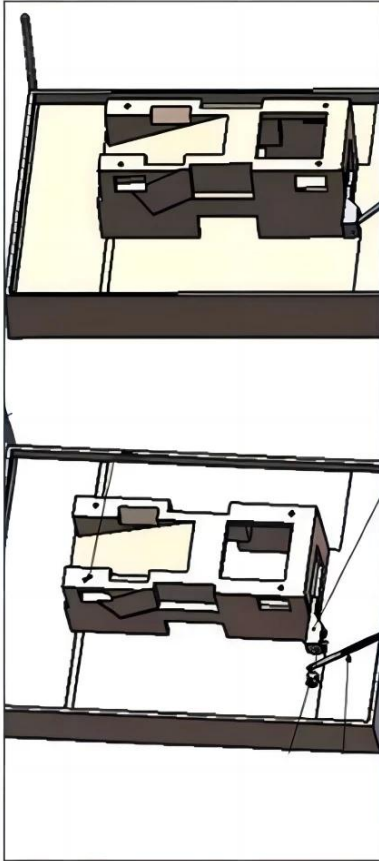

Heading machine is the fastener industry whole plant equipment with automatic thread rolling machine supporting the professional equipment cold heading machine. Its purpose is selected, such as carbon steel, stainless steel, aluminum, copper and other metal wire, with a suitable mold, according to wire made allowable pressure ratio in effect under the slider crank rod driven,

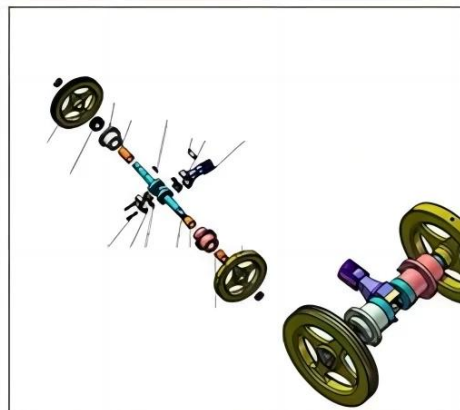
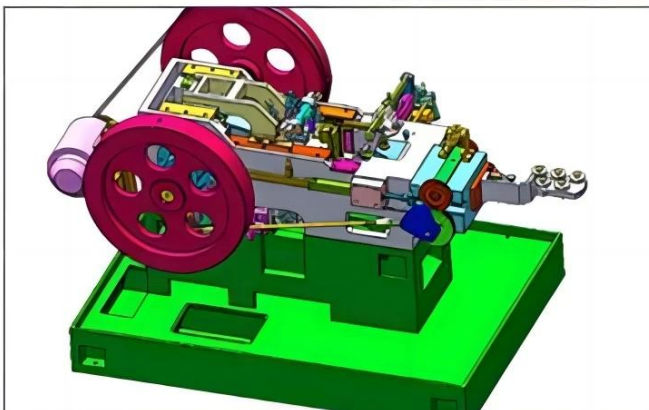
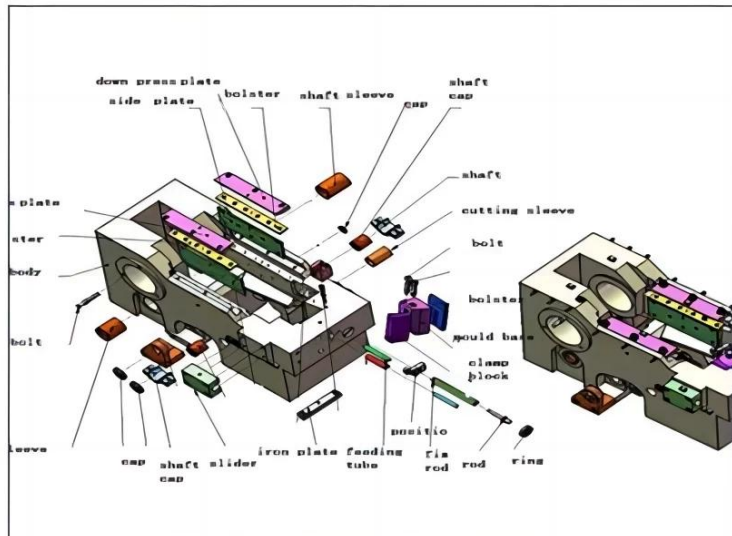
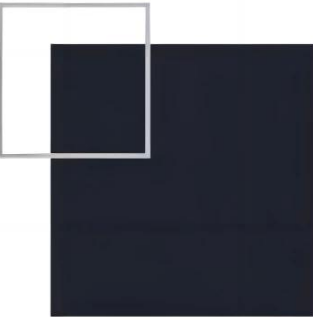

SAFETY INSTRUCTIONS

The head machine is a professional cold upsetting forming machine which is matched with automatic wire rolling machine in the whole plant of fastener industry.

Its purpose is to the selected such as carbon steel, stainless steel, aluminum, copper and other metal wire, with appropriate mould, according to the allowable pressure wire than, under the effect of crankshaft connecting rod drive the slider, automated, fast after the required size of the wire will be automatically shear, extrusion in the mould for needed fastener head type, stem diameter, facilitate thread rolling, or become a qualified rivet type fastener. The heading machine automatically processes the wire into semi-finished products.



- 1 cornice del corpo è realizzato in saldatura a piastra di ferro
- 2 pezzi di ricambio sono realizzati dal casting
- 3 parti interne sono realizzate in acciaio cuscinetto



SCREW MAKER

One die two blow heading machine. widely used to produce standard and non-standard screw. the machine is easy to operate and stable in performance



PRODUCTION AREA

Provide You With A Variety Of Products Meet
The Different Needs Of Customers



Screw With Washer



Multi-stage
Special Shaped Screw



Flange Head Screw



Ordinary Screw



Miniature Screw



Semi-hollow Rivet

DETAILS SHOW

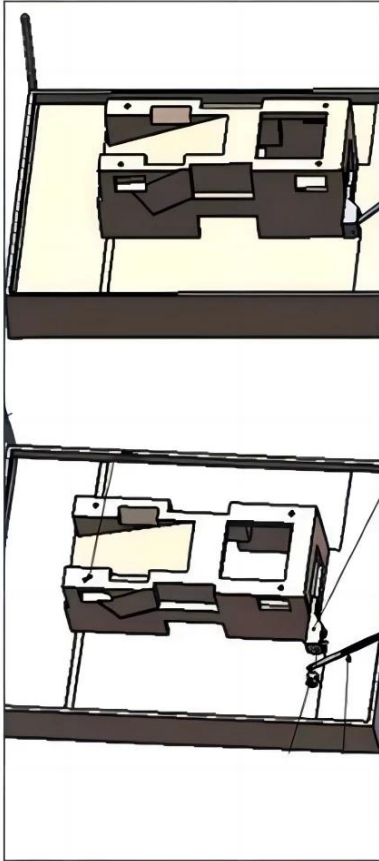

Heading machine is the fastener industry whole plant equipment with automatic thread rolling machine supporting the professional equipment cold heading machine. Its purpose is selected, such as carbon steel, stainless steel, aluminum, copper and other metal wire, with a suitable mold, according to wire made allowable pressure ratio in effect under the slider crank rod driven,

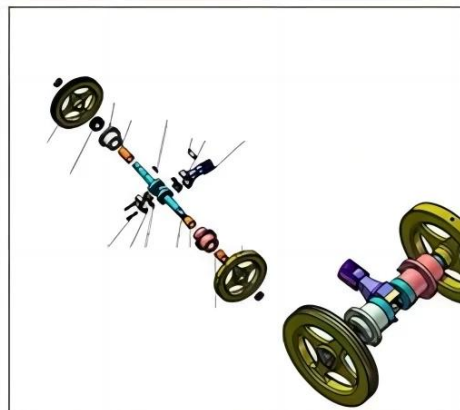
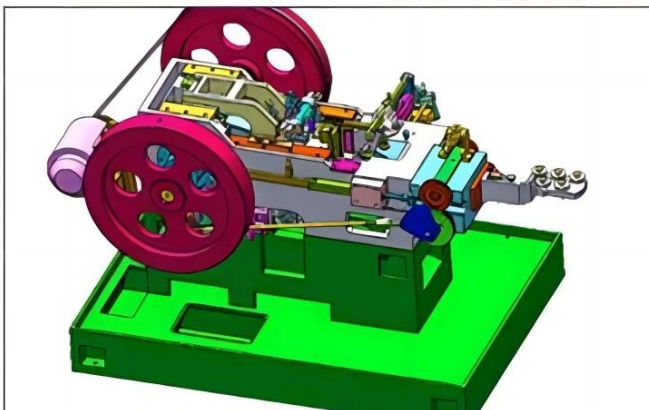
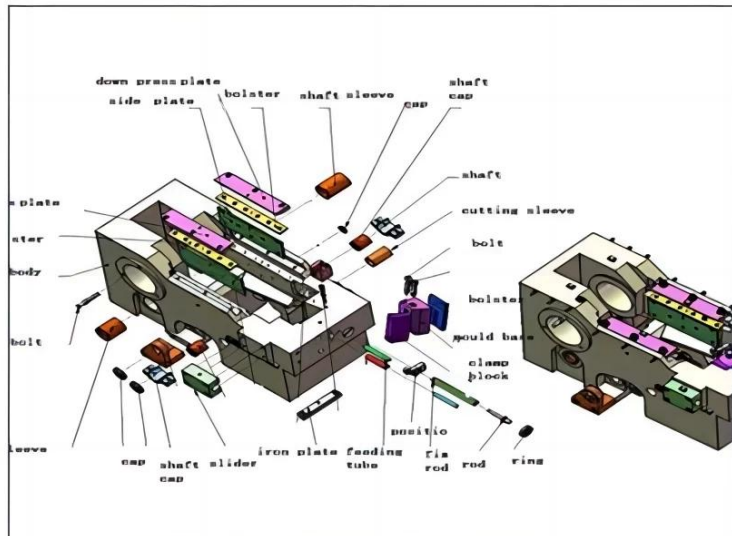
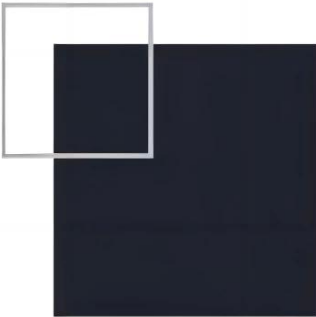

SAFETY INSTRUCTIONS

The head machine is a professional cold upsetting forming machine which is matched with automatic wire rolling machine in the whole plant of fastener industry.

Its purpose is to the selected such as carbon steel, stainless steel, aluminum, copper and other metal wire, with appropriate mould, according to the allowable pressure wire than, under the effect of crank-shaft connecting rod drive the slider, automated, fast after the required size of the wire will be automatically shear, extrusion in the mould for needed fastener head type, stem diameter, facilitate thread rolling, or become a qualified rivet type fastener. The heading machine automatically processes the wire into semi-finished products.

