

Funkcja maszyny:

1. Te zimne maszyny do tytułu są w pełni automatyczne i łatwe w obsłudze. Prawie nie ma treningu i są one wyposażone w formy solidne. Mogą być puste dla śrub, śrub, nitów i innych podobnych elementów. Mechanizm cięcia i nokaut ma bezpieczny sprzęt. Jeśli w maszynie wystąpi jakakolwiek nieprawidłowa funkcja, może zapobiec żadnym poważnym wypadkom.
2. W pierwszym i drugim uderzeniu dokonano pozytywnego meczu z nokautem, aby wyeliminować możliwość przyklejenia tych pięści podczas operacji.
3. Na pewnym dodatkowym ładowaniu maszyna będzie wyposażona w sprzęgło pneumatyczne i automatyczny scentralizowany układ smarowania, aby zapewnić wystarczającą ilość smarowania dla wszystkich powierzchni łożysk.



PRODUCTION AREA

Provide You With A Variety Of Products Meet
The Different Needs Of Customers



Screw With Washer



Multi-stage
Special Shaped Screw



Flange Head Screw



Ordinary Screw



Miniature Screw



Semi-hollow Rivet

DETAILS SHOW

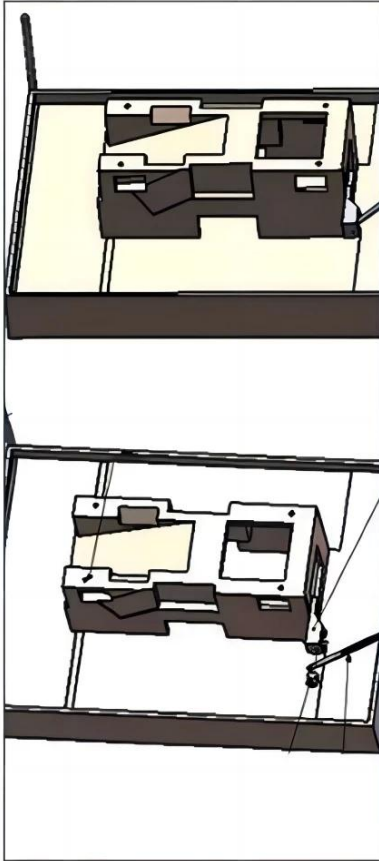

Heading machine is the fastener industry whole plant equipment with automatic thread rolling machine supporting the professional equipment cold heading machine. Its purpose is selected, such as carbon steel, stainless steel, aluminum, copper and other metal wire, with a suitable mold, according to wire made allowable pressure ratio in effect under the slider crank rod driven,

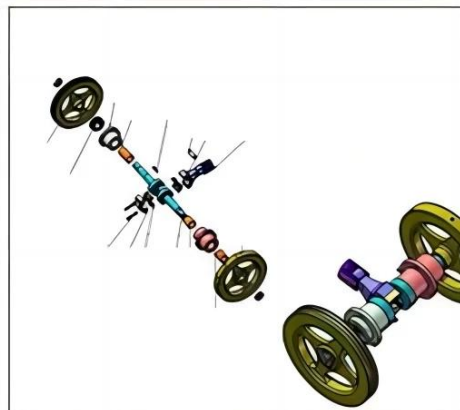
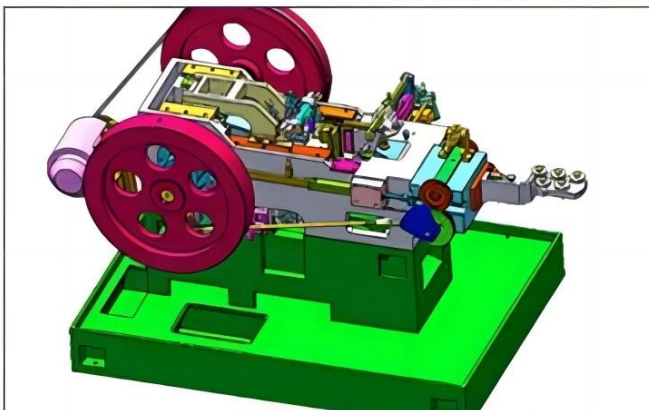
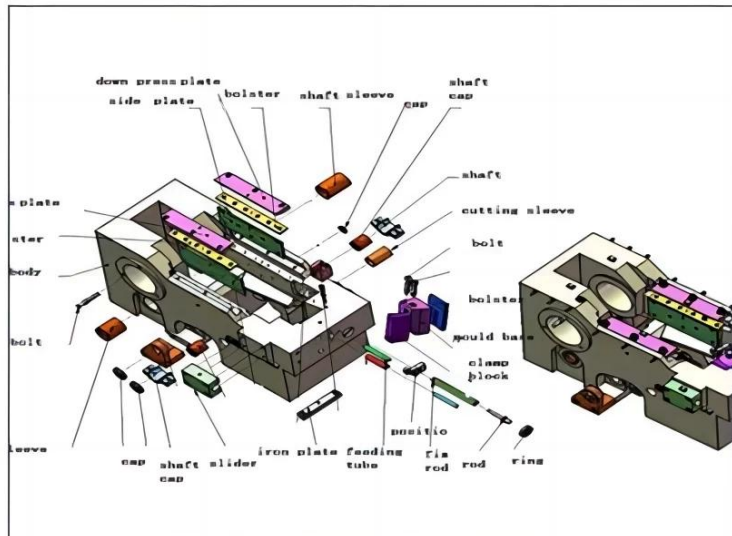
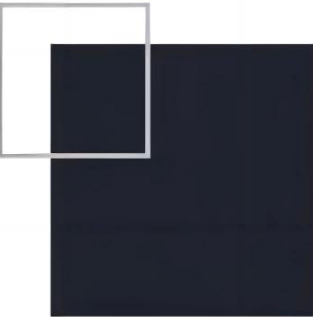

SAFETY INSTRUCTIONS

The head machine is a professional cold upsetting forming machine which is matched with automatic wire rolling machine in the whole plant of fastener industry.

Its purpose is to the selected such as carbon steel, stainless steel, aluminum, copper and other metal wire, with appropriate mould, according to the allowable pressure wire than, under the effect of crank-shaft connecting rod drive the slider, automated, fast after the required size of the wire will be automatically shear, extrusion in the mould for needed fastener head type, stem diameter, facilitate thread rolling, or become a qualified rivet type fastener. The heading machine automatically processes the wire into semi-finished products.



- 1 rama nadwozia jest wykonana z żelaznego spawania płytki
- Dwie części zamienne wykonane są z castingu
- 3 Wewnętrzne wykonane jest ze stali łożyskowej



SCREW MAKER

One die two blow heading machine. widely used to produce standard and non-standard screw. the machine is easy to operate and stable in performance



PRODUCTION AREA

Provide You With A Variety Of Products Meet
The Different Needs Of Customers



Screw With Washer



Multi-stage
Special Shaped Screw



Flange Head Screw



Ordinary Screw



Miniature Screw



Semi-hollow Rivet

DETAILS SHOW

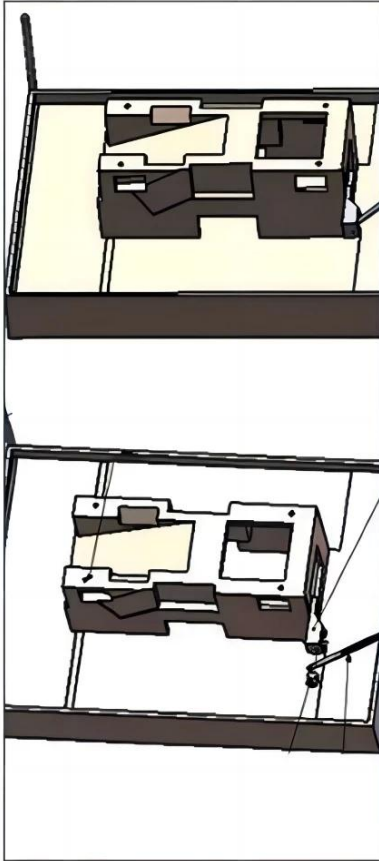

Heading machine is the fastener industry whole plant equipment with automatic thread rolling machine supporting the professional equipment cold heading machine. Its purpose is selected, such as carbon steel, stainless steel, aluminum, copper and other metal wire, with a suitable mold, according to wire made allowable pressure ratio in effect under the slider crank rod driven,

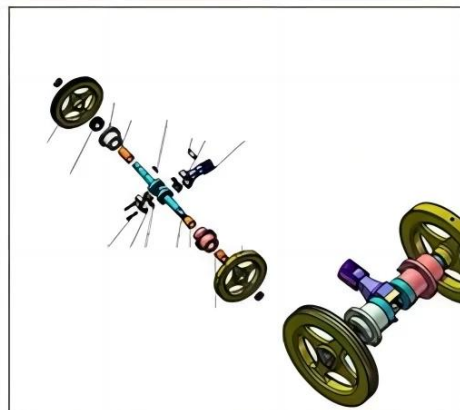
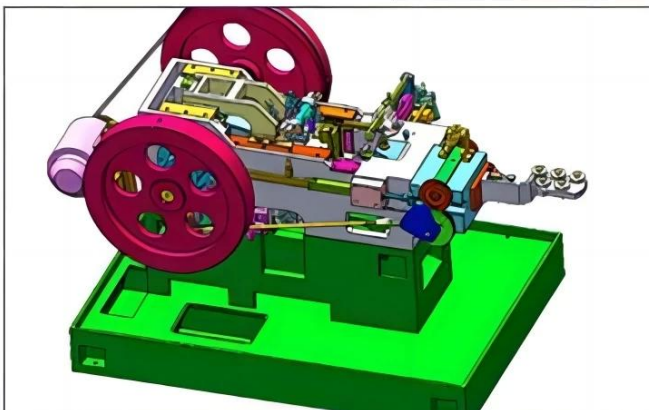
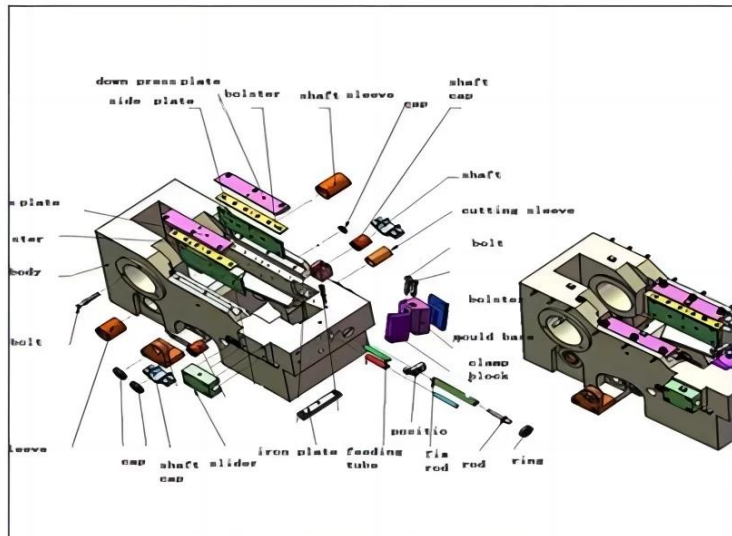
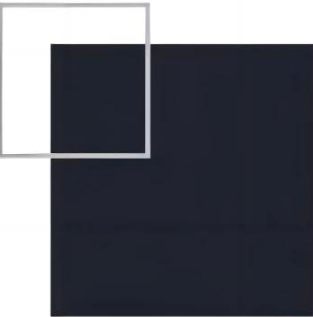

SAFETY INSTRUCTIONS

The head machine is a professional cold upsetting forming machine which is matched with automatic wire rolling machine in the whole plant of fastener industry.

Its purpose is to the selected such as carbon steel, stainless steel, aluminum, copper and other metal wire, with appropriate mould, according to the allowable pressure wire than, under the effect of crank-shaft connecting rod drive the slider, automated, fast after the required size of the wire will be automatically shear, extrusion in the mould for needed fastener head type, stem diameter, facilitate thread rolling, or become a qualified rivet type fastener. The heading machine automatically processes the wire into semi-finished products.

