

Well Tipo de forno de recozimento ELECTRIC

Well Type Electric Annealing Furnace



Liner of Well Type Electric Annealing Furnace



Well Type Electric Annealing Furnace (Main Furnace)



Electric Control Cabinet



Blower

Aplicação: Aplicado principalmente no esferoidização recozimento de bobina de fio de aço de baixo

carbono, aço, e aço do rolamento.

Cumprir a exigência profunda transformação das propriedades mecânicas do aço após heatment. Ele adquire descarbonização não-oxidação, a uniformidade do tecido esferoidização e boa qualidade de deformação plástica a frio (como estampagem e forjamento a frio).

Bem estrutura do tipo pode ser enterrado no subsolo, por isso ocupa pequena área; adota aquecimento elétrico e do processo heatment automática.

O revestimento do forno adota fibra completo, eficiência térmica e conservação de energia altamente promovido. O topo do forno é equipado com ventilador forte convecção de modo que a uniformidade da temperatura do forno todo é bom (+ - 5 °C).; adoção de gás de protecção e não-oxidação heatment para reduzir a perda de metal; material de alimentação é conveniente.

loadage acima é para fio de ferro para sua referência. As mudanças loadage acordo com Dia, altura e peso de fios de ferro.

ZD-8355型井式超强对流球化退火炉结构示意图

ZD-8355 Type supercon type spheroidizing Annealing furnace schematic diagram

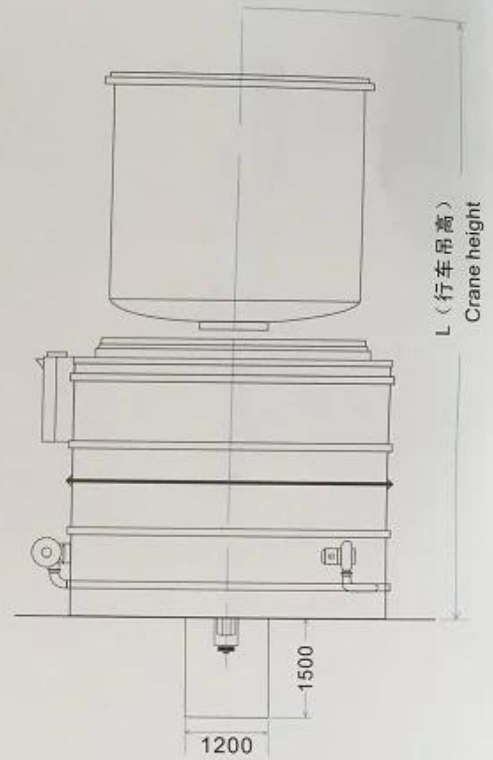
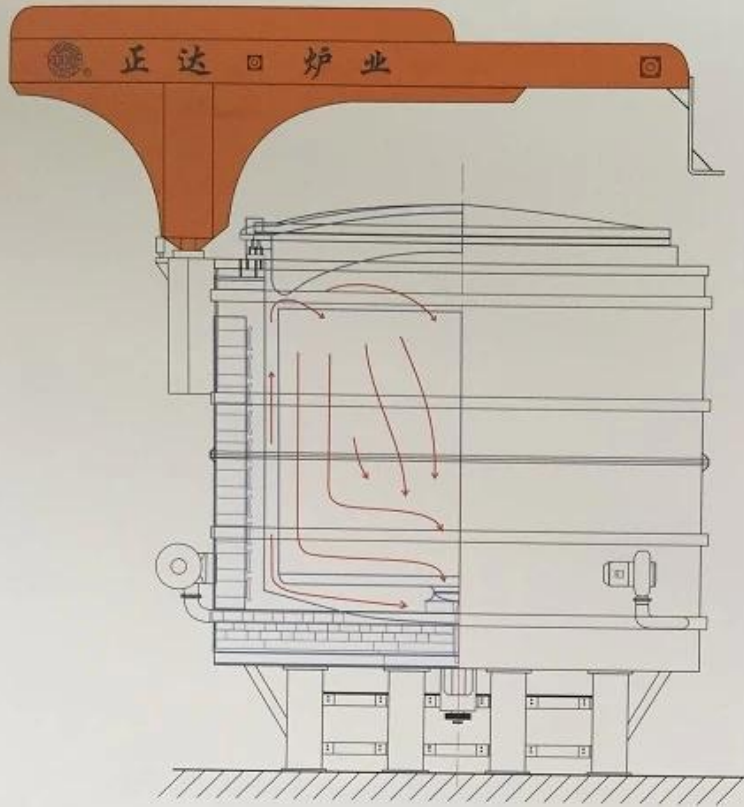

炉体安装吊高 (无脚架)
Installation lifting of furnace body

组成部件 Components



炉盖
The furnace cover



导流板
Air deflector



置料架
Loading frame



波纹桶成型
Corrugated molding



电加热炉
Electric heating furnace



波纹桶
Corrugated bucket



用于标准件行业球化炉
Used for fastener industry



用于汽配行业球化炉
Used for the auto parts industry



用于五金工具行业球化炉
Used for the hardware tool industry



用于轴承行业球化炉
Used for the bearing industry

超强对流型井式球化退火炉相关尺寸一览表(电加热型)
The relevant size list (Electric heating)

单位: mm

| 型号 Type | 使用直径 Use diameter | 使用高度 Use height | 炉体外径 Furnace body diameter | 炉体高度 Furnace body height | 总高度 Total height | 脚架高 Tripod height | 行车吊高 Crane height | | 地坑尺寸 Pit size | 维修坑尺寸 Repair pit size | 炉体总重 Furnace weight | 行车荷重 Driving load | 功率 Power | 装载量 Capacity |
|------------|----------------------|--------------------|-------------------------------|-----------------------------|---------------------|----------------------|-----------------------------------|---------------------------------|------------------|------------------------------|------------------------|----------------------|-------------|-----------------|
| | A | B | D | B | E | F | 有脚 size supporting table | 无脚 No supporting table | G×J | 长×宽×深 Length×Width×Height | (吨) Ton | (吨) Ton | (千瓦) Kw | (吨) Ton |
| 8355-1 | 2200 | 2000 | 3378 | 3200 | 6930 | 1500 | 7800 | 6300 | 5200×5200 | 5200×1200×1500 | 19.8 | 5 | 240 | 2~8 |
| | 2200 | 3000 | 3378 | 4200 | 7930 | 1500 | 8800 | 7300 | 5200×5200 | 5200×1200×1500 | 22.8 | 5 | 240 | 2~8 |
| 8355-2 | 2450 | 2000 | 3678 | 3200 | 6930 | 1500 | 7800 | 6300 | 5450×5200 | 5450×1200×1500 | 21.8 | 5 | 280 | 4~14 |
| | 2450 | 3000 | 3678 | 4200 | 7930 | 1500 | 8800 | 7300 | 5450×5200 | 5450×1200×1500 | 25.8 | 5 | 280 | 4~14 |
| 8355-3 | 2800 | 2000 | 3978 | 3200 | 6930 | 1500 | 7800 | 6300 | 5800×5800 | 5800×1200×1500 | 26.2 | 5 | 400 | 4~14 |
| | 2800 | 3000 | 3978 | 4200 | 7930 | 1500 | 8800 | 7300 | 5800×5800 | 5800×1200×1500 | 28.5 | 5 | 400 | 8~16 |
| 8355-4 | 3200 | 2000 | 4378 | 3200 | 6930 | 1500 | 7800 | 6300 | 6200×6200 | 6200×1200×1500 | 29.3 | 10 | 500 | 8~22 |
| | 3200 | 3000 | 4378 | 4200 | 7930 | 1500 | 9800 | 8300 | 6200×6200 | 6200×1200×1500 | 32.5 | 10 | 500 | 8~22 |
| 8355-5 | 3600 | 2000 | 4778 | 3200 | 6930 | 1500 | 8050 | 6550 | 6500×6500 | 6500×1200×1500 | 34.3 | 10 | 640 | 8~32 |
| | 3600 | 3000 | 4778 | 4200 | 7930 | 1500 | 9950 | 8450 | 6500×6500 | 6500×1200×1500 | 35.2 | 10 | 640 | 8~32 |
| 8355-6 | 3700 | 2000 | 4978 | 3200 | 6930 | 1500 | 8050 | 6550 | 6700×6700 | 6700×1200×1500 | 35.3 | 10 | 720 | 8~36 |
| | 3700 | 3000 | 4978 | 4200 | 7930 | 1500 | 9990 | 8450 | 6700×6700 | 6700×1200×1500 | 36.3 | 10 | 720 | 8~36 |



Para mais informações, por favor visite nosso website: www.rainbowtechnology.net
Tem alguma dúvida, não hesite em contactar-me.
Muitas felicidades,
Vera

WhatsApp é: 8618704610523

Nós chat: vera5266

QQ: 417651303