

Функции машины:

1. Эти машины холодного направления полностью автоматические и простые в работе с небольшим обучением, оснащенные сплошной матрицей для производства пустых для болтов, винтов, заклепок и других подобных компонентов. Механизм отключения и нокаутирования имеет безопасные устройства, которые останутся какой-либо серьезную аварию, если на машинах возникнет какая-либо ненормальная функция.
2. Положительное положение было сделано на первом и 2-м ударах, чтобы устранить возможность прилипания деталей в эти удары во время операций.
3. На некоторых дополнительных зарядах машины будут оснащены пневматическими сцеплениями и автоматическими централизованными системами смазков, которые обеспечивают достаточное количество смазки для всей поверхности подшипника.



SCREW MAKER

One die two blow heading machine. widely used to produce standard and non-standard screw. the machine is easy to operate and stable in performance



PRODUCTION AREA

Provide You With A Variety Of Products Meet
The Different Needs Of Customers



Screw With Washer



Multi-stage
Special Shaped Screw



Flange Head Screw



Ordinary Screw



Miniature Screw



Semi-hollow Rivet

DETAILS SHOW

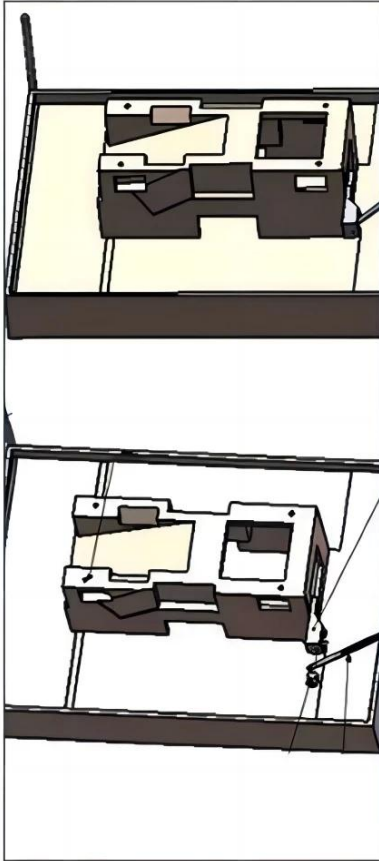

Heading machine is the fastener industry whole plant equipment with automatic thread rolling machine supporting the professional equipment cold heading machine. Its purpose is selected, such as carbon steel, stainless steel, aluminum, copper and other metal wire, with a suitable mold, according to wire made allowable pressure ratio in effect under the slider crank rod driven,

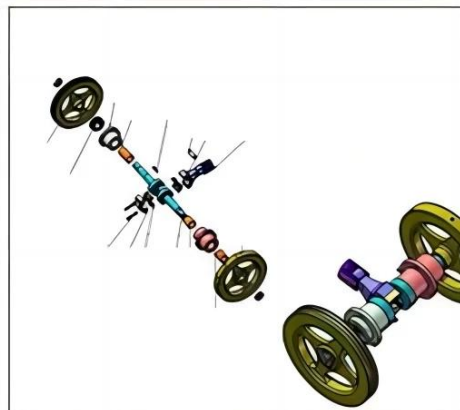
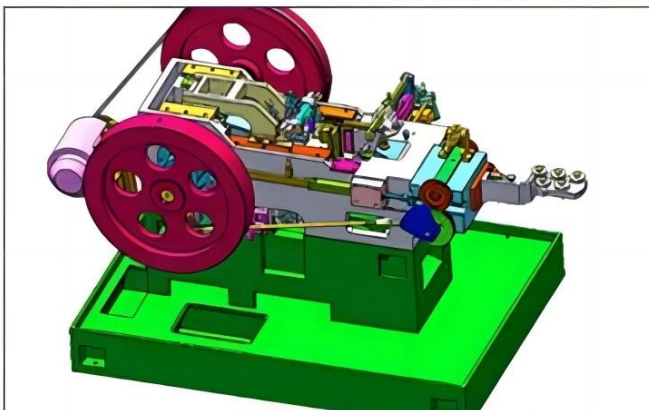
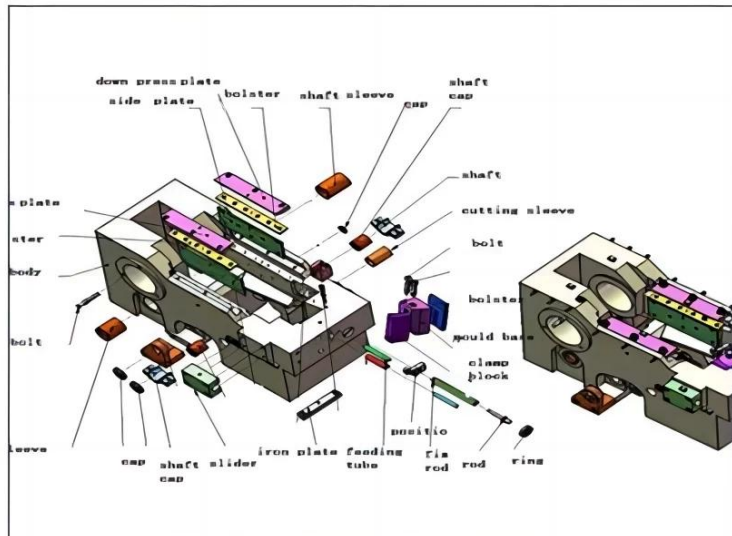
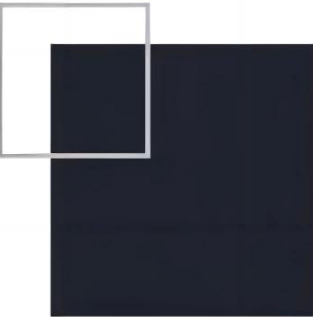

SAFETY INSTRUCTIONS

The head machine is a professional cold upsetting forming machine which is matched with automatic wire rolling machine in the whole plant of fastener industry.

Its purpose is to the selected such as carbon steel, stainless steel, aluminum, copper and other metal wire, with appropriate mould, according to the allowable pressure wire than, under the effect of crankshaft connecting rod drive the slider, automated, fast after the required size of the wire will be automatically shear, extrusion in the mould for needed fastener head type, stem diameter, facilitate thread rolling, or become a qualified rivet type fastener. The heading machine automatically processes the wire into semi-finished products.



- 1 рама тела изготовлена из железной пластины
- 2 запасных частей сделаны из кастинга
- 3 внутренние детали изготовлены из стали подшипника



SCREW MAKER

One die two blow heading machine. widely used to produce standard and non-standard screw. the machine is easy to operate and stable in performance



PRODUCTION AREA

Provide You With A Variety Of Products Meet
The Different Needs Of Customers

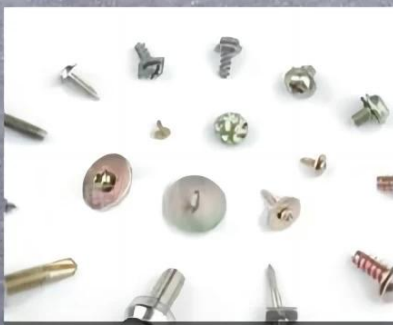

Screw With Washer



Multi-stage
Special Shaped Screw

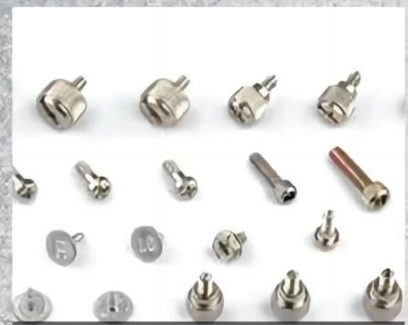

Flange Head Screw



Ordinary Screw

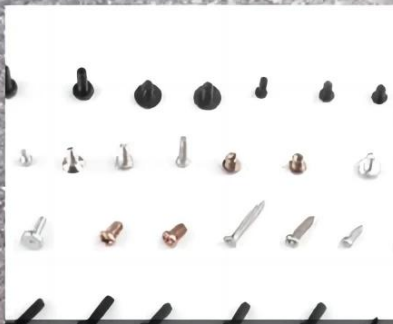

Miniature Screw



Semi-hollow Rivet

DETAILS SHOW

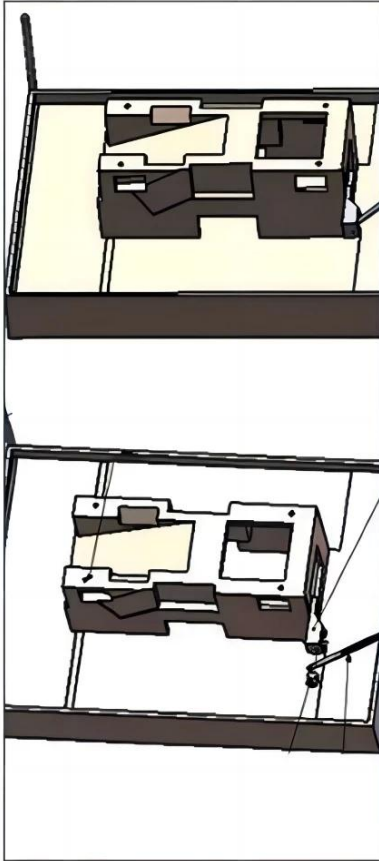

Heading machine is the fastener industry whole plant equipment with automatic thread rolling machine supporting the professional equipment cold heading machine. Its purpose is selected, such as carbon steel, stainless steel, aluminum, copper and other metal wire, with a suitable mold, according to wire made allowable pressure ratio in effect under the slider crank rod driven,

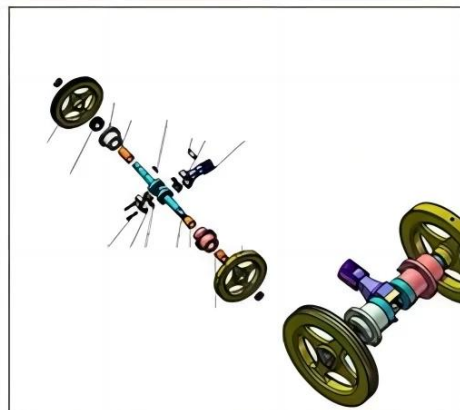
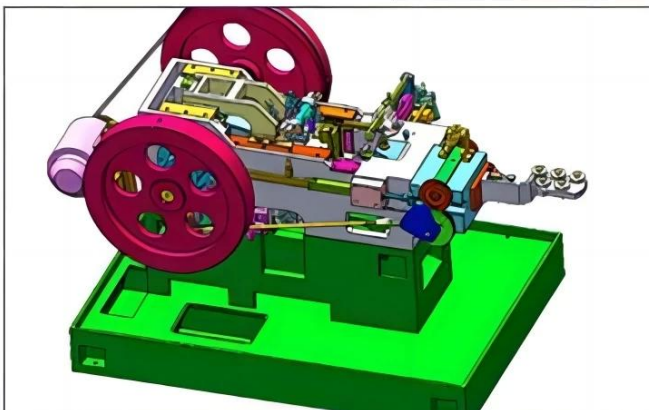
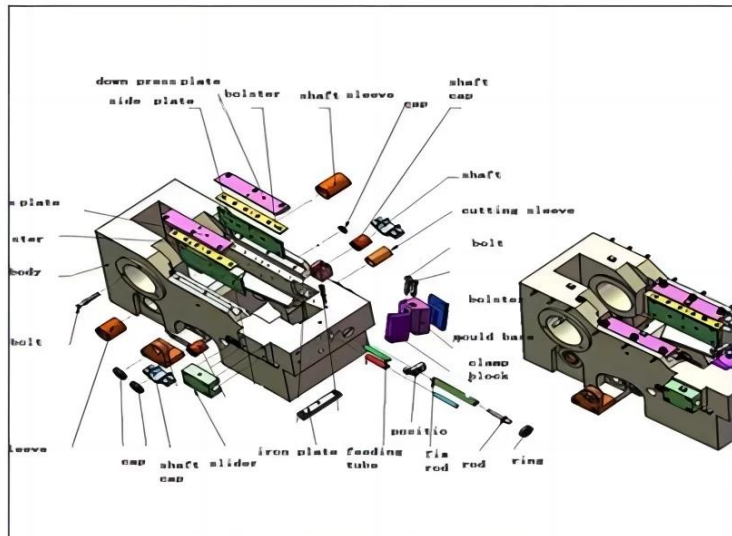
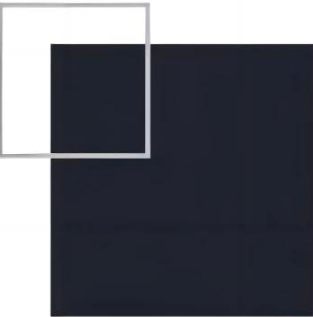

SAFETY INSTRUCTIONS

The head machine is a professional cold upsetting forming machine which is matched with automatic wire rolling machine in the whole plant of fastener industry.

Its purpose is to the selected such as carbon steel, stainless steel, aluminum, copper and other metal wire, with appropriate mould, according to the allowable pressure wire than, under the effect of crank-shaft connecting rod drive the slider, automated, fast after the required size of the wire will be automatically shear, extrusion in the mould for needed fastener head type, stem diameter, facilitate thread rolling, or become a qualified rivet type fastener. The heading machine automatically processes the wire into semi-finished products.

