



# PRODUCTION AREA

Provide You With A Variety Of Products Meet  
The Different Needs Of Customers



Screw With Washer



Multi-stage  
Special Shaped Screw



Flange Head Screw



Ordinary Screw



Miniature Screw



Semi-hollow Rivet



# DETAILS SHOW

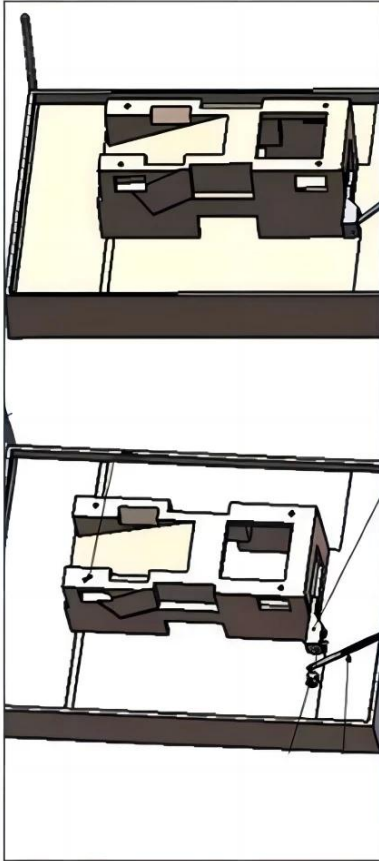

Heading machine is the fastener industry whole plant equipment with automatic thread rolling machine supporting the professional equipment cold heading machine. Its purpose is selected, such as carbon steel, stainless steel, aluminum, copper and other metal wire, with a suitable mold, according to wire made allowable pressure ratio in effect under the slider crank rod driven,

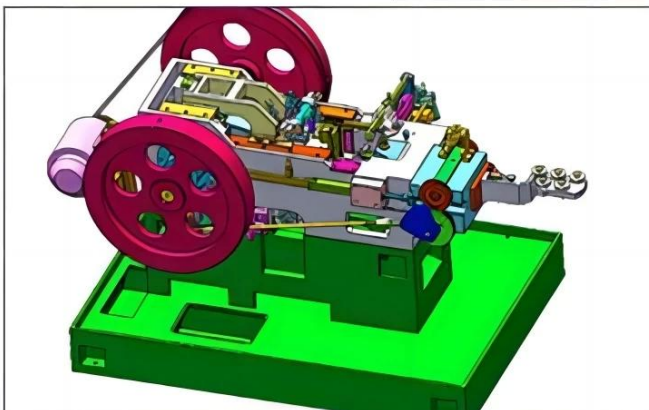
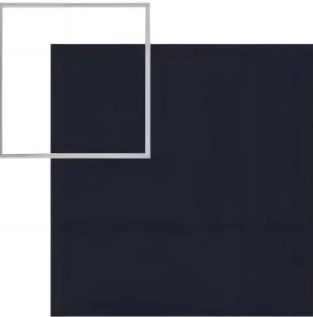

# SAFETY INSTRUCTIONS

The head machine is a professional cold upsetting forming machine which is matched with automatic wire rolling machine in the whole plant of fastener industry.

Its purpose is to the selected such as carbon steel, stainless steel, aluminum, copper and other metal wire, with appropriate mould, according to the allowable pressure wire than, under the effect of crank-shaft connecting rod drive the slider, automated, fast after the required size of the wire will be automatically shear, extrusion in the mould for needed fastener head type, stem diameter, facilitate thread rolling, or become a qualified rivet type fastener. The heading machine automatically processes the wire into semi-finished products.







# PRODUCTION AREA

Provide You With A Variety Of Products Meet  
The Different Needs Of Customers



Screw With Washer



Multi-stage  
Special Shaped Screw



Flange Head Screw



Ordinary Screw



Miniature Screw



Semi-hollow Rivet



# DETAILS SHOW

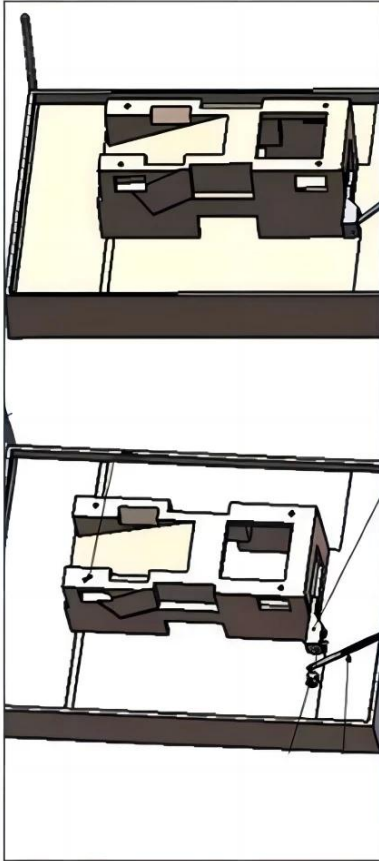

Heading machine is the fastener industry whole plant equipment with automatic thread rolling machine supporting the professional equipment cold heading machine. Its purpose is selected, such as carbon steel, stainless steel, aluminum, copper and other metal wire, with a suitable mold, according to wire made allowable pressure ratio in effect under the slider crank rod driven,

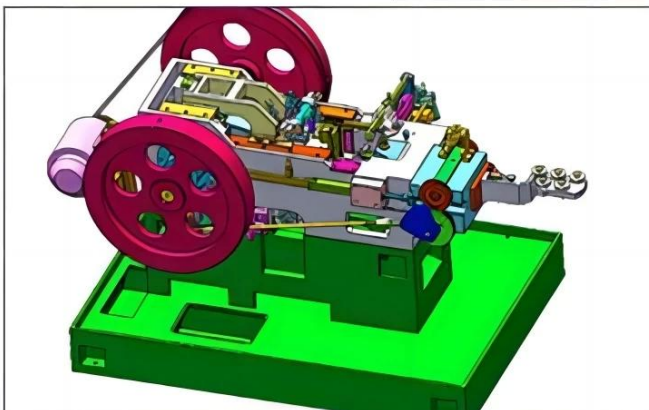
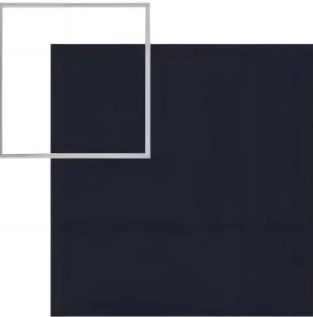

# SAFETY INSTRUCTIONS

The head machine is a professional cold upsetting forming machine which is matched with automatic wire rolling machine in the whole plant of fastener industry.

Its purpose is to the selected such as carbon steel, stainless steel, aluminum, copper and other metal wire, with appropriate mould, according to the allowable pressure wire than, under the effect of crank-shaft connecting rod drive the slider, automated, fast after the required size of the wire will be automatically shear, extrusion in the mould for needed fastener head type, stem diameter, facilitate thread rolling, or become a qualified rivet type fastener. The heading machine automatically processes the wire into semi-finished products.

