

## Makine Özellikleri:

1. Bu soğuk başlık makineleri tamamen otomatiktir ve civatalar, vidalar, perçinler ve diğer benzer bileşenler için boş üretmek için katı kalıp ile donatılmış az eğitim ile çalıştırılması kolaydır. Kesme ve nakavt mekanizması, makinelerde herhangi bir anormal fonksiyon meydana gelirse, herhangi bir büyük kazayı durduracak güvenli bir şekilde cihazlara sahiptir.
2. Operasyonlar sırasında bu yumruklara yapışma olasılığını ortadan kaldırmak için 1. ve 2. yumruklarda olumlu bir nakavt hükümleri yapılmıştır.
3. Bazı ekstra yüklerde makineler, tüm yatak yüzeyine yeterli miktarda yağlama sağlayan pnömatik debriyaj ve otomatik merkezi yağlama sistemleri ile donatılacaktır.



# PRODUCTION AREA

Provide You With A Variety Of Products Meet  
The Different Needs Of Customers

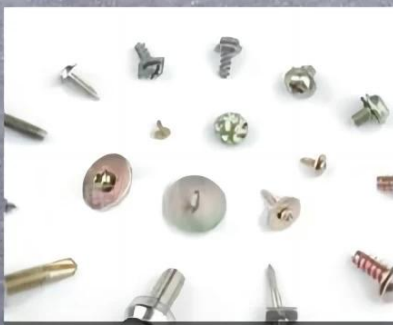

Screw With Washer



Multi-stage  
Special Shaped Screw

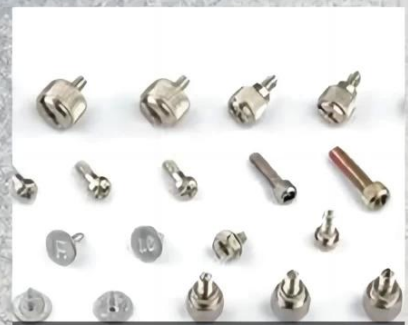

Flange Head Screw



Ordinary Screw

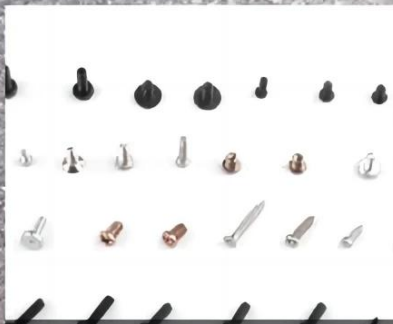

Miniature Screw



Semi-hollow Rivet

# DETAILS SHOW

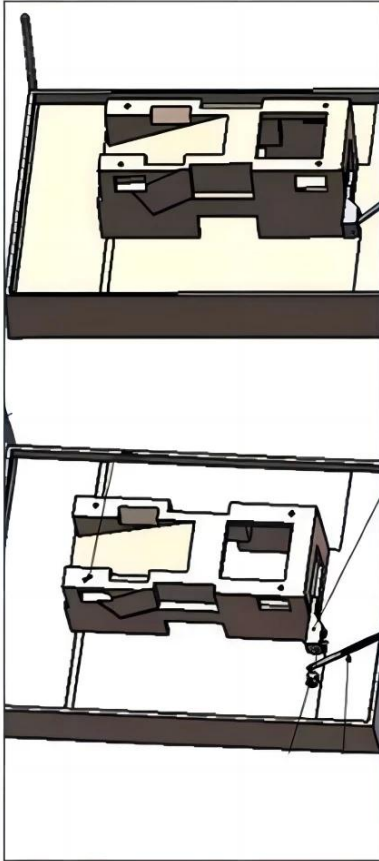

Heading machine is the fastener industry whole plant equipment with automatic thread rolling machine supporting the professional equipment cold heading machine. Its purpose is selected, such as carbon steel, stainless steel, aluminum, copper and other metal wire, with a suitable mold, according to wire made allowable pressure ratio in effect under the slider crank rod driven,

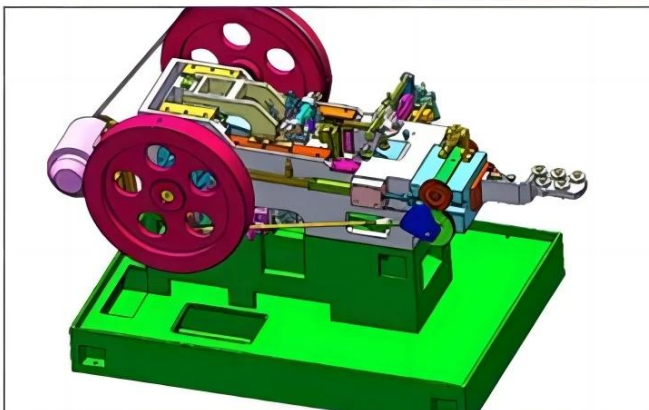
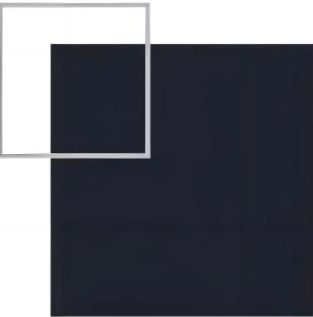

# SAFETY INSTRUCTIONS

The head machine is a professional cold upsetting forming machine which is matched with automatic wire rolling machine in the whole plant of fastener industry.

Its purpose is to the selected such as carbon steel, stainless steel, aluminum, copper and other metal wire, with appropriate mould, according to the allowable pressure wire than, under the effect of crank-shaft connecting rod drive the slider, automated, fast after the required size of the wire will be automatically shear, extrusion in the mould for needed fastener head type, stem diameter, facilitate thread rolling, or become a qualified rivet type fastener. The heading machine automatically processes the wire into semi-finished products.



- 1 gövde çerçevesi demir plaka kaynağından yapılmıştır
- 2 yedek parça dökümden yapılır
- 3 iç kısım rulman çeliğinden yapılmıştır



# SCREW MAKER

One die two blow heading machine. widely used to produce standard and non-standard screw. the machine is easy to operate and stable in performance



# PRODUCTION AREA

Provide You With A Variety Of Products Meet  
The Different Needs Of Customers

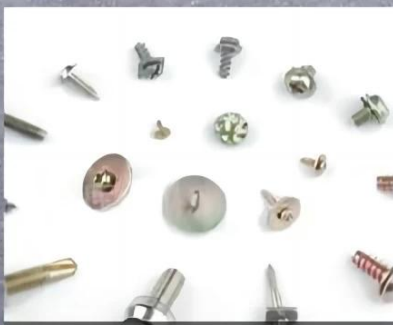

Screw With Washer



Multi-stage  
Special Shaped Screw

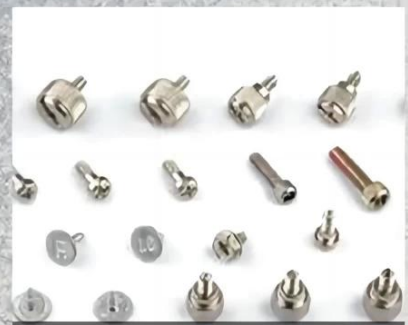

Flange Head Screw



Ordinary Screw

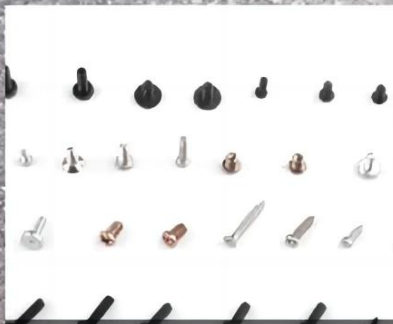

Miniature Screw



Semi-hollow Rivet

# DETAILS SHOW

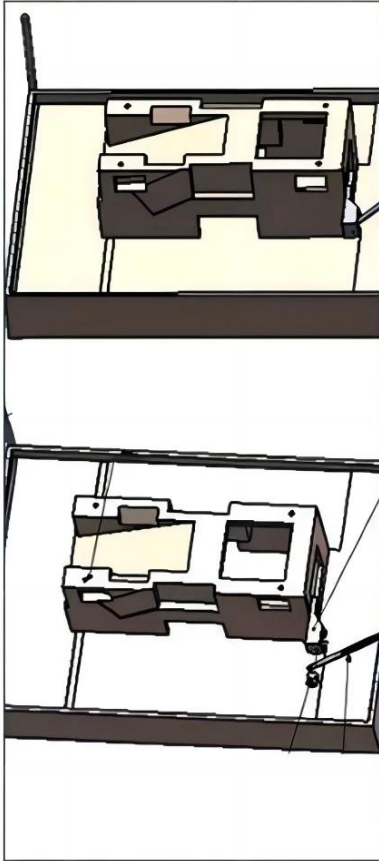

Heading machine is the fastener industry whole plant equipment with automatic thread rolling machine supporting the professional equipment cold heading machine. Its purpose is selected, such as carbon steel, stainless steel, aluminum, copper and other metal wire, with a suitable mold, according to wire made allowable pressure ratio in effect under the slider crank rod driven,

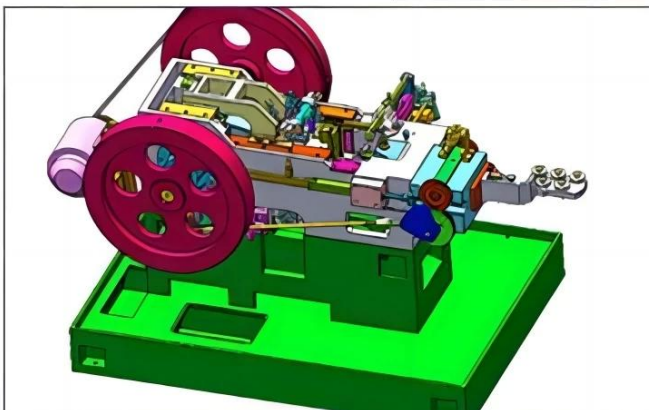
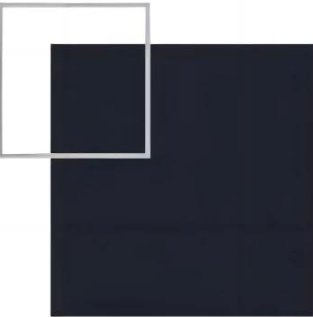

# SAFETY INSTRUCTIONS

The head machine is a professional cold upsetting forming machine which is matched with automatic wire rolling machine in the whole plant of fastener industry.

Its purpose is to the selected such as carbon steel, stainless steel, aluminum, copper and other metal wire, with appropriate mould, according to the allowable pressure wire than, under the effect of crank-shaft connecting rod drive the slider, automated, fast after the required size of the wire will be automatically shear, extrusion in the mould for needed fastener head type, stem diameter, facilitate thread rolling, or become a qualified rivet type fastener. The heading machine automatically processes the wire into semi-finished products.

