

KUYU ELEKTRİK tavlama fırınını TİPİ

Well Type Electric Annealing Furnace



Liner of Well Type Electric Annealing Furnace



Well Type Electric Annealing Furnace (Main Furnace)



Electric Control Cabinet



Blower

Uygulama: Ağırlıklı düşük karbon çelik, alaşımli çelik ve rulman çelik tel bobini için tavlama

küreleştirme uygulanan.

Bu heatment sonra çeliğin mekanik özellikleri derin işleme gereksinimini karşılar.

Non-oksidasyon decarbonization, küreleştirme doku bütünlüğü ve (örneğin damgalama ve soğuk dövme gibi) soğuk plastik deformasyon kaliteli kazanır.

Peki tipi yapı yeraltında gömülü, bu yüzden küçük alanı kaplar olabilir; elektriksiz ısıtma ve otomatik heatment sürecini benimser.

fırın astar tam lif, ısı verimliliği ve enerji tasarrufu yüksek terfi benimser. fırın üst güçlü konveksiyon üfleyici ile donatılmıştır

böylece bütün fırının ısı dağılımı iyidir (+ - 5 °C.); Koruyucu gaz ve metal kaybını azaltmak için non-oksidasyon heatment benimseyerek; malzemenin cihaza uygundur.

Yukarıdaki loadage referans için demir tel içindir. loadage değişiklikleri Dia, Yükseklik ve demir tel Ağırlık göre.

ZD-8355型井式超强对流球化退火炉结构示意图

ZD-8355 Type supercon type spheroidizing Annealing furnace schematic diagram

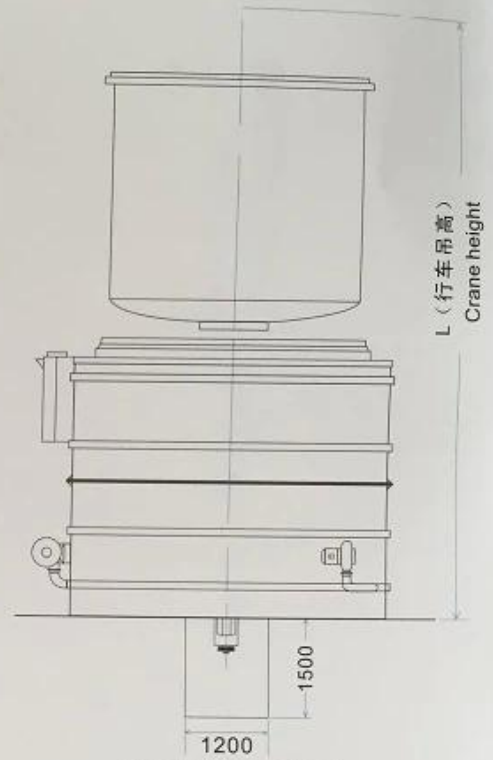
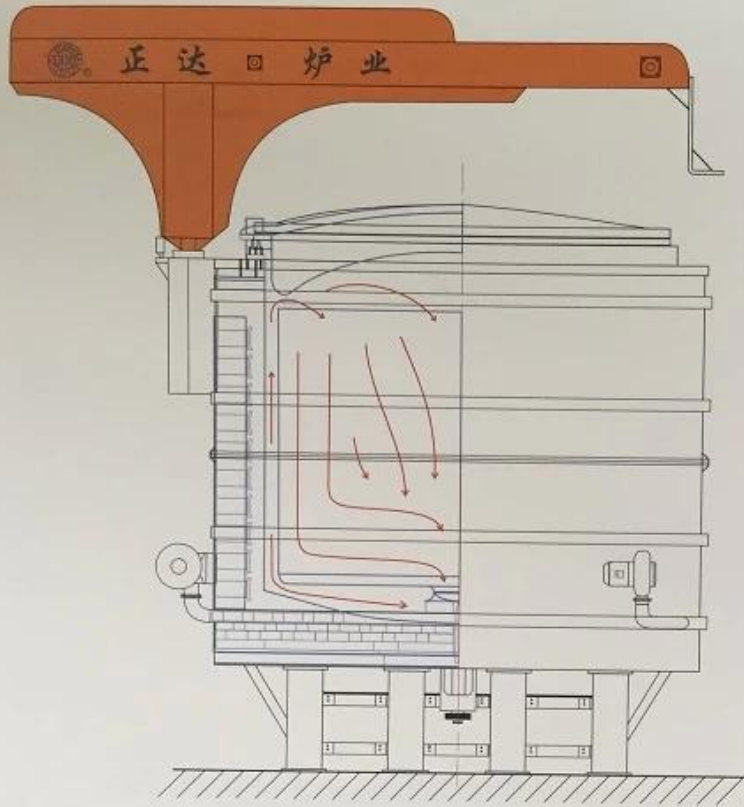

炉体安装吊高 (无脚架)
Installation lifting of furnace body

组成部件 Components



炉盖
The furnace cover



导流板
Air deflector



置料架
Loading frame



波纹桶成型
Corrugated molding



电加热炉
Electric heating furnace



波纹桶
Corrugated bucket



用于标准件行业球化炉
Used for fastner industry



用于汽配行业球化炉
Used for the auto parts industry



用于五金工具行业球化炉
Used for the hardware tool industry



用于轴承行业球化炉
Used for the bearing industry

超强对流型井式球化退火炉相关尺寸一览表(电加热型)
The relevant size list (Electric heating)

单位: mm

型号 Type	使用直径 Use diameter	使用高度 Use height	炉体外径 Furnace body diameter	炉体高度 Furnace body height	总高度 Total height	脚架高 Tripod height	行车吊高 Crane height		地坑尺寸 Pit size	维修坑尺寸 Repair pit size	炉体总重 Furnace weight	行车荷重 Driving load	功率 Power	装载量 Capacity
	A	B	D	B	E	F	有脚 size supporting table	无脚 No supporting table	G×J	长×宽×深 Lenght×Width×Height	(吨) Ton	(吨) Ton	(千瓦) Kw	(吨) Ton
8355-1	2200	2000	3378	3200	6930	1500	7800	6300	5200×5200	5200×1200×1500	19.8	5	240	2~8
	2200	3000	3378	4200	7930	1500	8800	7300	5200×5200	5200×1200×1500	22.8	5	240	2~8
8355-2	2450	2000	3678	3200	6930	1500	7800	6300	5450×5200	5450×1200×1500	21.8	5	280	4~14
	2450	3000	3678	4200	7930	1500	8800	7300	5450×5200	5450×1200×1500	25.8	5	280	4~14
8355-3	2800	2000	3978	3200	6930	1500	7800	6300	5800×5800	5800×1200×1500	26.2	5	400	4~14
	2800	3000	3978	4200	7930	1500	8800	7300	5800×5800	5800×1200×1500	28.5	5	400	8~16
8355-4	3200	2000	4378	3200	6930	1500	7800	6300	6200×6200	6200×1200×1500	29.3	10	500	8~22
	3200	3000	4378	4200	7930	1500	9800	8300	6200×6200	6200×1200×1500	32.5	10	500	8~22
8355-5	3600	2000	4778	3200	6930	1500	8050	6550	6500×6500	6500×1200×1500	34.3	10	640	8~32
	3600	3000	4778	4200	7930	1500	9950	8450	6500×6500	6500×1200×1500	35.2	10	640	8~32
8355-6	3700	2000	4978	3200	6930	1500	8050	6550	6700×6700	6700×1200×1500	35.3	10	720	8~36
	3700	3000	4978	4200	7930	1500	9990	8450	6700×6700	6700×1200×1500	36.3	10	720	8~36



www.rainbowtechnology.net: Daha fazla bilgi için web sitemizi ziyaret ediniz
Herhangi bir sorunuz varsa, bana ulaşmaktan çekinmeyin.
En iyi dileklerle,
vera

WhatsApp ise: 8618704610523
Biz sohbet: vera5266
QQ: 417651303